

Application Note



Using 2310 with option 01 to make Wideband Noise Measurements on TETRA Transmitters



TETRA conformance specification ETS EN 300 394-1 V2.1.1 (2000-09) defines minimum performance requirements for mobile terminal equipment and base stations.

Introduction

The TETRA standard is designed to share spectrum allocation with analog systems and therefore the performance specified for TETRA transmitters is onerous in order

to minimize interference. This in turn places high demands on equipment designed to measure transmitter performance. Of particular interest here are the requirements for wideband noise emissions far from carrier.

This application note describes how IFR 2310 can be used to make wideband noise measurements accurately, fast and as per the conformance requirement. A description of the measurement requirements as defined in ETS EN 300 394-1 is given along with a practical implementation of these requirements in IFR 2310 together with some typical measurement data.

2310 is a purpose designed TETRA Signal Analyzer that provides a complete set of TETRA transmitter measurements implemented in accordance with the conformance specification ETS EN 300 394-1. The virtues of the 2310 are its outstanding speed of measurement, high accuracy and ease of use.

Wideband Noise requirements for TETRA Transmitters

ETS EN 300-394-1 defines the technical characteristics of both mobiles and base stations together with the radio test methods to be used in type testing. For each parameter, the specification includes a definition for the minimum performance, the test method to be used and the acceptable uncertainty level of the measurement equipment.

For wideband noise the standard requires the measurement be made through a TETRA filter. This is a root Nyquist filter that has 3 dB bandwidth of 18 kHz and an alpha of 0.35. The wideband noise performance limit is not a fixed value but varies as a function of both transmitter power class and offset from carrier. The limit table specified in the conformance specification is shown in Table 1 below.

Frequency offset from carrier	Wideband Noise minimum requirement		
	Mobile Station (MS)		Base Station all classes & MS power level > 5 W
	Power level ≤ 1 W	Power level > 1W	
> frb	-100 dBc	-100 dBc	-100 dBc
500 kHz - frb	-80 dBc	-85 dBc	-90 dBc
250 kHz - 500 kHz	-80 dBc	-83 dBc	-85 dBc
100 kHz - 250 kHz	-75 dBc	-78 dBc	-80 dBc

Table 1 - ETS EN 300-394-1 Requirements for wideband noise.

Note: frb denotes the frequency offset corresponding to the near edge of the received band or 5 MHz (10 MHz for frequencies above 520 MHz) whichever is greater. All level are expressed in dBc relative to the actual transmitted power level, and in any case no limit greater than -55 dBm for offsets £frb or -70 dBm for offsets >frb shall apply.

The measurement method specified in the standard states that the test system shall calculate the average noise power over at least 20 TETRA bursts. The measurement samples must be taken synchronously with the transmitted burst. Furthermore, sample data must be cover at least 200 symbols within each burst.

The measure of average transmitter power level will be used as the 0 dB reference for the wideband noise measurements.

Within the bands specified in Table 1, measurements must be made at 112.5 kHz, 262.5 kHz, 512.5 kHz and frb+12.5 kHz.

The conformance specification for acceptable uncertainty introduced by the measurement equipment used to test wideband noise is:

- RF power relative to 0 dB reference:
 - 0 dBc to -45 dBc +/- 1.0 dB
 - < -45 dBc to -105 dBc +/- 1.5 dB

Limitations of Conventional Test Methods

A general purpose spectrum analyzer is often considered appropriate for making measurements such as wideband noise. However, spectrum analyzers suffer a number of deficiencies as a result of their basic design which make them unsuitable for this measurement.

General purpose spectrum analyzers do not incorporate a Nyquist filter. This is not possible to implement accurately as an analogue filter. Instead a spectrum analyzer uses swept measurement with a narrow IF resolution bandwidth (RBW) filter much smaller than Nyquist bandwidth. The responses are integrated across the required Nyquist bandwidth and weighted to approximate an otherwise true Nyquist response.

The first drawback of this approach is speed. Secondly the dynamic range of measurement must be greater than 100 dB. Swept measurement is based upon resolution bandwidth, which is just a fraction of Nyquist bandwidth. Hence, the dynamic range of swept measurement has to be even greater than integrated measurement through Nyquist filter. e.g. If Nyquist bandwidth is 18 kHz and filter bandwidth of swept measurement is 180 Hz then for integrated measurement to have 100 dB dynamic range implies that measurement through 180 Hz filter has to be 120 dB. This presents significant challenge for log amp and detectors of any spectrum analyzer.

TETRA requires that the wideband noise measurement is performed whilst synchronized to the burst carrier. A normal spectrum analyzers is unable to maintain synchronization with the carrier while tuned to the offset frequency. What is the problem with just sweeping spectrum analyzer slowly across spectrum?. Firstly, swept spectrum analyzers only see one portion of the spectrum at a time and therefore might miss the occurrence of the burst. Secondly sweeping very slowly to ensure that LO dwells long enough on each channel frequency to see TDMA burst, will require a low video filter bandwidth. Video filtering a log value gives the wrong answer. Furthermore any rise in noise level during the burst period will be rejected by the action of the video filter. The default video filter setting can usually be replaced by a user specified value. If a video bandwidth much greater than resolution bandwidth is selected then this introduces another variable, namely there will many video samples for each pixel on the spectrum analyzer screen. Most spectrum analyzers use a selection algorithm, which attempts to pick out the sample peaks. Again this leads to ambiguity when trying to measure noise power which is compounded by the fact that different analyzer manufacturers use different algorithms to select the video samples to display.

Many modern day spectrum analyzers provide an external trigger input. This can be used to gate the measurement so that the analyzer only sweeps when the TETRA transmitter bursts. This overcomes some of the drawbacks of using a spectrum analyzer but a gated sweep requires the addition of a second receiver to be tuned to the carrier or the supply or external triggering from the D.U.T

All of these problems make general purpose spec analyzers unsuitable for TETRA wideband noise measurement.

An Overview of 2310 and its block diagram

A simplified block diagram of 2310 is shown in fig 1. 2310 has a high power input and a low power input selected from the RF input switch. High power TETRA transmitter classes in the range +3 dBm to +46 dBm are catered for on the high power input and low power TETRA transmitter classes in the range -20 dBm to +27 dBm are catered for on the low power input. A variable attenuator is used to condition the TETRA carrier to be within a desired power band before it is mixed to an intermediate frequency (IF) of

10.71 MHz. The IF signal is amplified to match the operating point of the instrument analog to digital converter. 2310 uses a novel converter architecture, namely a single bit band pass delta sigma converter. This patented, converter architecture was developed because of its outstanding dynamic range which makes it uniquely suitable to the rigorous demands of TETRA transmitter testing. The pass band of the converter is 300 kHz, which allows twelve TETRA channel bandwidths to be digitized. Once digitized, the IF is passed to dedicated signal processing hardware that generates a filtered I/Q data stream. The IQ data is passed to an Analog Devices SHARC DSP that runs the TETRA measurement algorithms.

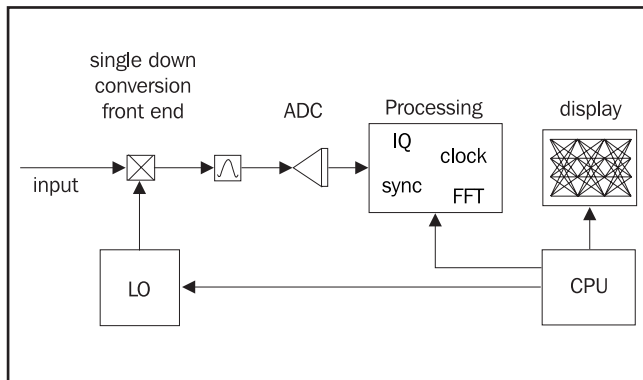

Figure 1 - 2310 basic block diagram

When a mixer is used to frequency convert a RF signal to an IF there are two RF frequencies that will equally well convert to the same IF. Both RF frequencies are separated from the local oscillator by a frequency separation equal to the IF frequency. Fig 2 shows the desired RF signal and the unwanted image. With a receiver architecture like that of 2310 it is difficult to determine whether the signal on the mixer's IF port originates from the RF band of interest or whether it is an image response.

2310's simple single stage downconverter offers limited image frequency rejection. The more complicated approach taken by many spectrum analyzers of first up mixing to a high first IF, (i.e. an LO frequency greater than the maximum input frequency of interest) followed by a second stage mix down to a low IF provides greater image rejection but at the expense of poorer accuracy, lower dynamic range and higher complexity than achieved in 2310.

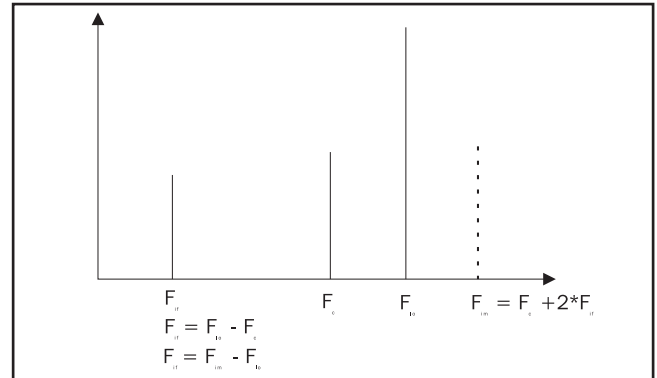

Figure 2 - Derivation of image frequency

TETRA Wideband Noise Measurement using 2310

2310's excellent power accuracy and linearity make it ideally suited to make wideband noise measurements. To obtain synchronization to the TETRA burst the instrument must be first tuned to receive the on-channel of the transmitter. Depending upon the mode of operation, synchronization is performed either on the underlying data within the TETRA burst or as a power ramp detection. If synchronization to the data is selected, then the first task for the measurement algorithm is to demodulate the TETRA training sequence in real time. This enables the measurement process to identify the current position within the TETRA slot and to set an accurate internal timing reference running. This timing reference will enable the measurement software to predict when the TETRA transmitter is bursting and so avoid the need for a separate second receiver. The instrument can now be tuned to look at wideband noise components far from carrier and the incoming IQ data stream can be time gated with the instrument timing reference.

When configured for the majority of its TETRA measurements, the 2310 has a noise floor density of -128 dBc/Hz. This translates to an instrument noise contribution 85 dBc when measuring through the TETRA root Nyquist filter. The conformance specification calls for the wideband noise component to be measured across 200 symbols within the useful part of the burst averaged across at least 20 bursts. 2310 implements a root Nyquist filter in its measurement algorithm and can directly measure the true RMS noise power through this filter. This means that 2310 can comply with the conformance specification requirement of measuring the noise power variation against time and average the results over 20 bursts.

An instrument noise floor of -85 dBc allows 2310 to comfortably measure the TETRA adjacent channel power specification of -70 dBc and to measure the power profile requirement also set at -70 dBc. However the conformance specification for wideband noise calls for TETRA transmitters to comply with a -100 dBc limit. A measuring instrument used to check transmitter compliance to this specification must in turn have an internal noise floor that is even lower than the specification.

To enhance the instrument dynamic range required, 2310 incorporates a switched IF bandpass filter. This filter, which is positioned directly after the input mixer, allows the TETRA carrier to be measured at one level of sensitivity. When the instrument is

returned to the noise channel being measured the filter is switched in rejecting the high level carrier and instrument sensitivity is increased by raising the IF gain level. To optimize 2310's noise figure, its 65 dB step attenuator should be set to zero attenuation and it's IF amplifier set to the maximum value of 35 dB. Setting the attenuation to zero will raise the operating point of the mixer which will provide a higher dynamic range on the IF. The benefit of increasing the IF gain is that the front end noise will be amplified above the quantization noise of the ADC. This means that the ADC quantization noise no longer makes a significant contribution to the instrument noise figure. The level to which the IF gain can be increased is dependent upon the rejection of the carrier given by the filter. The danger in switching in too much IF gain is that the residual carrier will be amplified to levels where it will saturate the single bit converter. The practical impact of this is that as the noise measurement moves further away from the carrier, the greater the carrier rejection becomes, and the more sensitive the noise measurement can be made.

For carrier offsets greater than 250 kHz the dominant factor in limiting dynamic range becomes the noise floor of the local oscillator rather than a combination of front end noise and converter quantization noise. Reciprocal mixing between the local oscillator and the incoming TETRA carrier ensure that the IF noise floor does not fall below the local oscillator noise floor. However the local oscillator noise floor is more than -105 dBc when measured through a TETRA filter and therefore exceeds the transmitter specification.

Table 2 shows the variation in instrument sensitivity against offset from carrier. The TETRA wideband noise specification is shown in table 1. It can be seen that 2310's residual noise is below that of the TETRA specification for all offsets. 2310's residual noise, combined with its linearity, speed and ease of use make it well suited to measuring TETRA wideband noise.

Offset frequency	2310 Residual noise floor (18 kHz b/w)	
	Fc < 500 MHz	500 MHz < Fc < 1 GHz
100 kHz - 250 kHz	-88 dBc	-88 dBc
250 kHz - 500 kHz	-98 dBc	-98 dBc
500 kHz - 5 MHz	-100 dBc	-98 dBc
> 5 MHz	-105 dBc	-103.5 dBc

Table 2 - Residual noise floor of 2310

2310 Option 01 To Enhance Wideband Noise Measurement

Option 01 is designed to increase the maximum measurement range from -105 dBc to -110 dBc and thereby provide a 10 dB measurement standoff against ETSI requirement. Further more, image noise fold back from the transmitter sidebands is eliminated. Option 01 is a software upgrade to 2310 and provides the following features.

1. RF minimum frequency input is extended to 80 MHz*.
2. A new wideband measurement application mode providing up to -110 dBc residual noise floor.

In order for this option to work it must be used in conjunction with additional external RF components which form a low noise down converter to provide 2310 with a 80 MHz to 200 MHz RF input. These components are not supplied with the option.

* This is required only to utilize the 83 MHz bandpass filter described below.

Measurement Procedure For The Wideband Noise Measurement Option

This measurement procedure associated with option 01 uses components external to 2310 to enhance the performance. The measurement set up is shown below.

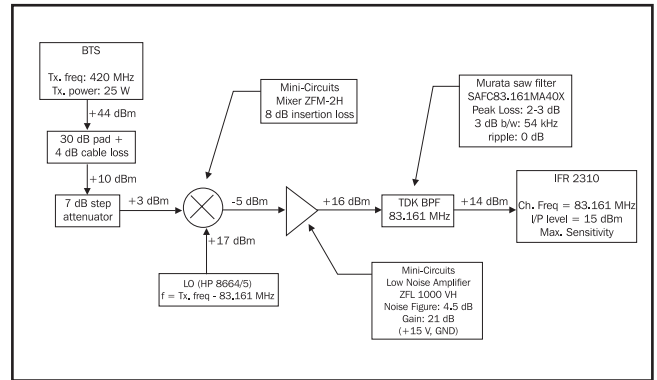

Figure 3 - Set-up for Enhanced Wideband Noise Measurement

The diagram shows the set-up for a BTS test case. The same configuration is used for both mobile and base stations. The difference lies in the attenuation required on the input to the external mixer.

The function of the external components is to produce an IF in the range of 80 to 200 MHz that is then fed to 2310 as the RF input. In this way sufficient selectivity is obtained to prevent D.U.T image noise compromising the measurement. i.e. With an externally generated IF of 80 MHz, the image product seen by 2310 is 160 MHz away. The noise profile of a TETRA transmitter will diminish sufficiently at that offset and consequently will not raise the noise floor seen at the 2310 10.7 MHz IF.

This external IF is generated using a single mix down stage followed by a low noise amplifier and bandpass filter. During the measurement process the external IF frequency that is being analyzed by 2310 is fixed and hence 2310's local oscillator remains fixed during the measurement.

It is important to minimize the SSB phase noise of the external LO to avoid generating noise contribution through reciprocal mixing between the LO and the TETRA TX input signal. Tests have shown that to achieve reliable results SSB phase noise should be better than -155 dBc/Hz at 5 MHz offset and -133 dBc at 100 kHz offset.

The measurement procedure starts by synchronizing 2310 to the TETRA carrier. This is done in the same manner as for the stand-alone wideband noise measurement. To obtain synchronization 2310 must receive the TETRA carrier. To do this, the external local oscillator must be set to mix the incoming RF carrier to an external IF equal to the center frequency of the bandpass filter. Once the external LO has been set, 2310 can be instructed to synchronize to the TETRA carrier with a single key press. In addition to setting a timing reference, 2310's synchronization process measures the amplitude of the carrier to act as a reference point for the measurement. (note a level offset value should be entered to

account for the additional path loss between the D.U.T and the 2310 RF input). The number of TETRA bursts captured and averaged to determine the power reference can be set by the user anywhere in the range of 1 to 200. Synchronization produces an accurate internal timing reference which is later used to ensure that the noise measurements made are synchronous with the transmitter burst. It is assumed that between generating synch timing and noise measurement, the transmitter timing remains unaltered.

The next step in the measurement process is to make a noise measurement. To do this the external LO must be retuned to mix the noise sideband of interest to the center frequency of the external IF. Before 2310 is instructed to make the noise measurement it must be told the approximate frequency offset of the noise channel to be measured. This ensures that 2310's hardware configuration is set optimally for each offset frequency. As the frequency offset increases the dynamic range demands increase and the hardware configuration adjusts to meet these demands. To specify the frequency offset, one of four offset bands is selected (as per table 1 above). Having specified the frequency offset, the noise measurement is initiated with a single key press. For each frequency offset the noise power is averaged across 20 data blocks that have been captured synchronous to the transmitter burst.

The noise measurement results can be displayed as a numeric result in a table or as a spectral trace annotated with the noise measurement. Checking against user defined limits is supported. Two limits are defined, a relative limit (dBc) and an absolute limit (dBm). As per the conformance standard, the less demanding of the two limits will be used as the threshold for the pass/fail indication.

Results

The noise floor of the measurement system is dependent upon both the 2310 and the specification of the external IF. Careful selection of the external IF components gives a measurement system residual noise floor 10 dB below the TETRA transmitter specification for all offset frequencies.

Table 3 - Residual noise floor of 2310 with external down converter

The results below are from measurements taken for a TETRA MS and BS using the example components shown in figure 3.

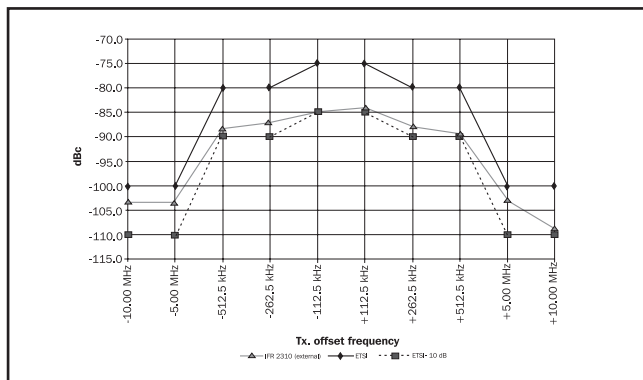

Figure 4 - IFR 2310 external mode performance vs. MS (1 W) ETSI limits

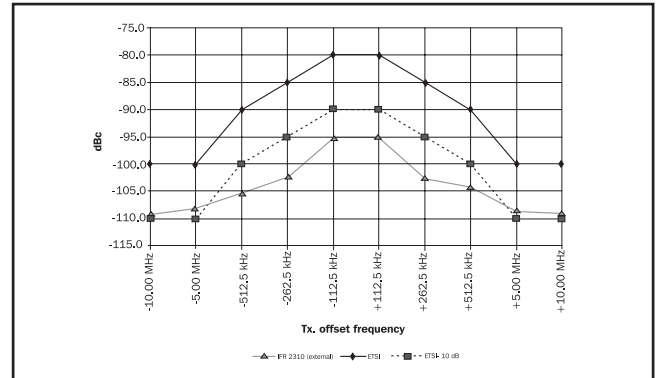

Figure 5 - IFR 2310 external mode performance vs. BS ETSI limits

Constraints on the wideband noise measurement

Any noise contribution from 2310 will add to the noise of the transmitter being measured. Therefore 2310's noise will add a positive offset to the noise reading. A 10 dB standoff between a specification point and the measuring instrument's floor is generally regarded as a good margin. A 10 dB standoff will give an uncertainty of 0.4 dB. As can be seen from tables 1 and 3, 2310 does not provide a 10 dB standoff for all noise offset frequencies. A standoff of 10 dB was taken as the target specification for wideband noise enhancement.

A block diagram of 2310 is given in fig 1. As was explained earlier, this architecture has many advantages for modulation analysis but a disadvantage is that it is not frequency selective and in particular has no image rejection. The IF frequency of 2310 is 10.71 MHz giving an image response 21.42 MHz away from the desired input signal. The PA in a TETRA transmitter must have sufficient bandwidth to cover the TETRA band of operation, typically a 20 MHz pass band. This together with some of the linearisation techniques used in TETRA amplifiers means that some TETRA transmitters have a flat noise floor pedestal extending a few 10's of MHz either side of the carrier. This is a problem when operating with an image frequency of 21.4 MHz away. If the image noise component is the same size as the noise offset being measured then the two will add to give a positive 3 dB error.

The PA's in TETRA transmitters have matching networks to ensure a flat response across the TETRA band. These networks roll off outside the TETRA band. Also, most TETRA transmitters contain harmonic filters. These two factors provide noise floor roll off as you move many 10's of MHz away from the carrier. Hence moving to a higher frequency IF with associated higher image frequency can remove the error introduced by operating with a 21.4 MHz image.

To enhance the wideband noise measurement external components are introduced to produce an IF in the range 80 to 200 MHz. A block diagram of the measurement set up is shown in fig 3. The minimum IF frequency of 80 MHz ensures a minimum offset of 160 MHz for the image. To produce the external IF the TETRA carrier is down converted using a mixer. Usually, the output desired from a mixer is a component at the difference frequency or the sum frequency of the signals at the RF and LO ports. However, mixers don't only produce an IF response at the sum and difference frequencies, unwanted components are found at:

$$F_{out} = m.F_{LO} \pm n.F_{RF}$$

Where m and n are integer values

Also, there will be LO and RF leakage across the mixer to the IF port.

The amplitude of these unwanted components will vary from mixer to mixer depending upon the mixer design. However in the context of making a noise measurement over a dynamic range of more than 100 dB, the number of significant harmonics can be very large. If the unwanted mixing products were left un-attenuated they could re-mix at the 2310 mixer to produce an unwanted component at the 2310 IF frequency of 10.71 MHz. To prevent this the external IF is filtered using a band pass filter. Making, the pass band of the order of a few hundred kilohertz wide has two advantages. First, it can be made wide enough to provide a flat pass band across the central TETRA channel while at the same time selective enough to reject unwanted mixing components. Second, the TETRA carrier will be rejected which will remove the reciprocal mixing component at 2310's mixer.

To achieve the target dynamic range care must be taken with both component selection and the operating levels for the external components. The external components must be selected to provide an IF which meets the target signal to noise ratio and at a sufficient power level that the noise floor of the external IF is not masked by 2310's noise floor.

If the IF signal level is made too low, the noise floor of the external components will degrade the SNR of the external IF. The noise floor of the external IF is set by the conversion loss and excess noise of the mixer, the noise figure of the amplifier and the conversion loss of the band pass filter. If the signal level being passed through the external components is too high, distortion will degrade the SNR on the external IF. The signal level is limited by the compression characteristics of the mixer and amplifier. A noise specification for the external IF system is given in Appendix 1.

To minimize the residual noise contribution from 2310, its front end gain should be set to its maximum value. This can only be done if the TETRA carrier can be sufficiently rejected to stop overload of the IF amplifier and ADC. For standalone noise measurement, 2310 has to rely solely on its internal IF bandpass filter to provide carrier rejection. When 2310's measurement capability is supplemented with a bandpass filter on the external IF, some additional carrier rejection will be provided. This improved composite selectivity allows 2310 hardware to be configured for minimum noise contribution at higher carrier powers and lower frequency offsets than would be the case for standalone measurement. This enhances the dynamic range of the noise measurement. To take advantage of the additional selectivity provided by the external band pass filter, the 2310 measurement software must assume a minimum filter selectivity. The minimum frequency response of the external IF is one of the external IF specification points given in Appendix 1.

Conclusion

Explanation and discussion of the difficulties associated with making wideband noise measurements on TETRA transmitters has been given. The advantages and disadvantages of spectrum analyzers versus IFR 2310 have been analyzed. A limitation of IFR 2310 has been shown relating to image noise together with a method to overcome this limitation based upon revised instrument firmware and external components which combine to produce a test solution for TETRA wideband noise measurement in circumstances where image noise is the limiting factor. Suitable specification for external components is supplied.

Option 01 may be introduced to 2310 as an upgrade. It is recommended this is performed during routine calibration although there should be no impact upon calibration validity.

Appendix 1 Specification for external components used with Wideband noise option

Specification for external IF system:

Noise floor

SNR

Frequency response -30 dB by 100 kHz

 -50 dB by 250 kHz

 -60 dB by 500 kHz

LO phase noise: -155 dBc/Hz at 5 MHz offset

 -133 dBc/Hz at 100 kHz offset

Example components:

1 dB Step attenuator

mixer Mini Circuits ZFM-2H

local oscillator Agilent 8664/5

low noise amplifier Mini Circuit FFL1000-VH

bandpass filter Murata SAW filter SAF
 C83.161MA40X

3 dB bandwidth 54 kHz

CHINA Beijing

Tel: [+86] (10) 6467 2716
Fax: [+86] (10) 6467 2821

CHINA Shanghai

Tel: [+86] (21) 6282 8001
Fax: [+86] (21) 62828 8002

FINLAND

Tel: [+358] (9) 2709 5541
Fax: [+358] (9) 804 2441

FRANCE

Tel: [+33] 1 60 79 96 00
Fax: [+33] 1 60 77 69 22

GERMANY

Tel: [+49] 8131 2926-0
Fax: [+49] 8131 2926-130

HONG KONG

Tel: [+852] 2832 7988
Fax: [+852] 2834 5364

INDIA

Tel: [+91] 80 5115 4501
Fax: [+91] 80 5115 4502

KOREA

Tel: [+82] (2) 3424 2719
Fax: [+82] (2) 3424 8620

SCANDINAVIA

Tel: [+45] 9614 0045
Fax: [+45] 9614 0047

SPAIN

Tel: [+34] (91) 640 11 34
Fax: [+34] (91) 640 06 40

UK Burnham

Tel: [+44] (0) 1628 604455
Fax: [+44] (0) 1628 662017

UK Stevenage

Tel: [+44] (0) 1438 742200
Fax: [+44] (0) 1438 727601
Freephone: 0800 282388

USA

Tel: [+1] (316) 522 4981
Fax: [+1] (316) 522 1360
Toll Free: 800 835 2352

As we are always seeking to improve our products, the information in this document gives only a general indication of the product capacity, performance and suitability, none of which shall form part of any contract. We reserve the right to make design changes without notice. All trademarks are acknowledged. Parent company Aeroflex, Inc. ©Aeroflex 2005.

www.aeroflex.com
info-test@aeroflex.com



Our passion for performance is defined by three attributes represented by these three icons: solution-minded, performance-driven and customer-focused.